

(12) UK Patent Application (19) GB (11) 2 288 014 (13) A

(43) Date of A Publication 04.10.1995

(21) Application No 9413398.0

(22) Date of Filing 04.07.1994

(30) Priority Data

(31) 9406485 (32) 31.03.1994 (33) GB

(71) Applicant(s)

Standard Products Limited

(Incorporated in the United Kingdom)

Dryden House, St. John's Street, HUNTINGDON,  
Cambridgeshire, PE18 6DD, United Kingdom

(72) Inventor(s)

Alan Charles Bickley

John Nicholas Hall

Laurence John Parnham

(74) Agent and/or Address for Service

Haseltine Lake & Co

Hazlitt House, 28 Southampton Buildings, Chancery  
Lane, LONDON, WC2A 1AT, United Kingdom

(51) INT CL<sup>6</sup>

G01V 8/16, E05F 15/20

(52) UK CL (Edition N)

G1A AA3 AG6 AG9 AME AR6 AR7 AT27 AT3 AT5  
E2M MAB MV  
U1S S1856

(56) Documents Cited

GB 2236388 A GB 2112934 A EP 0560047 A1  
EP 0259573 A1 DE 003107847 A1 US 4944116 A  
PATENT ABSTRACTS OF JAPAN vol 10 No 29 (M-451)  
& JP-A-60-185626 PATENTS ABSTRACTS OF JAPAN  
vol 8 No 253(M-339) & JP-A-59-128009

(58) Field of Search

UK CL (Edition M) E2M MAB, G1A AME, G3N NG2  
INT CL<sup>5</sup> E05F 15/00 15/20, G01V 9/04  
Online database: WPI

(54) Deformable sensor for powered vehicle window

(57) There is disclosed a deformation detection sensor comprising: an elongate element (2) including a deformable wall member which defines a radiation transmission path; a radiation transmission source (4) positioned to transmit radiation along the radiation transmission path; and a radiation detector (6) positioned to detect the radiation transmitted from the source (4) along the radiation transmission path; the arrangement being such that a deformation of the wall member of the elongate element (2) at least partially interrupts the radiation transmission path, whereby radiation being transmitted along said path to the detector (6) is attenuated.

Also disclosed is a motor vehicle having a body opening in which a closure member is movable towards a peripheral edge of the opening to close the opening, an electrically operated drive mechanism being provided to effect movement of the closure member. The peripheral edge of the body opening is provided with the above deformation detection sensor which may control said drive.

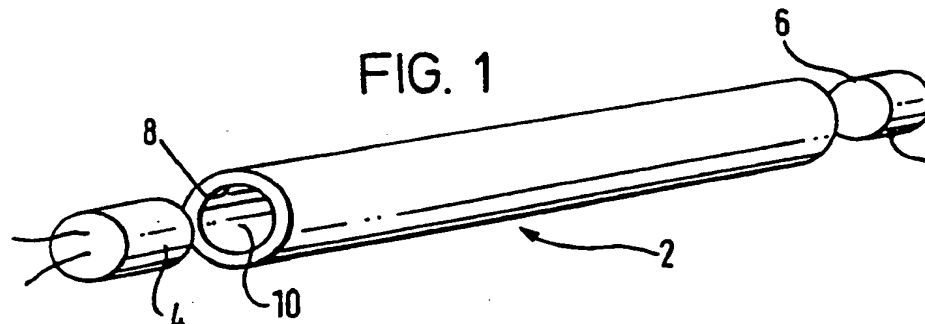

At least one drawing originally filed was informal and the print reproduced here is taken from a later filed formal copy.

The claims were filed later than the filing date within the period prescribed by Rule 25(1) of the Patents Rules 1990.

GB 2 288 014 A

1/2  
FIG. 1

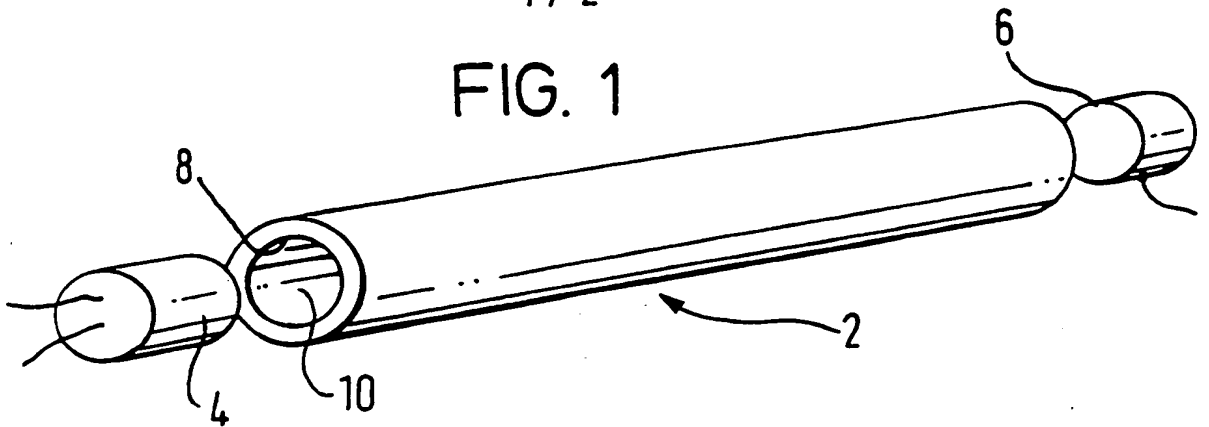

FIG. 2

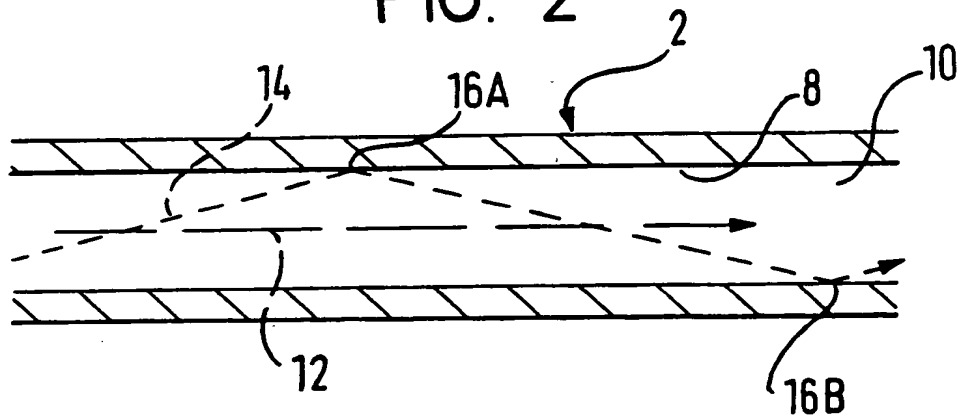

FIG. 3

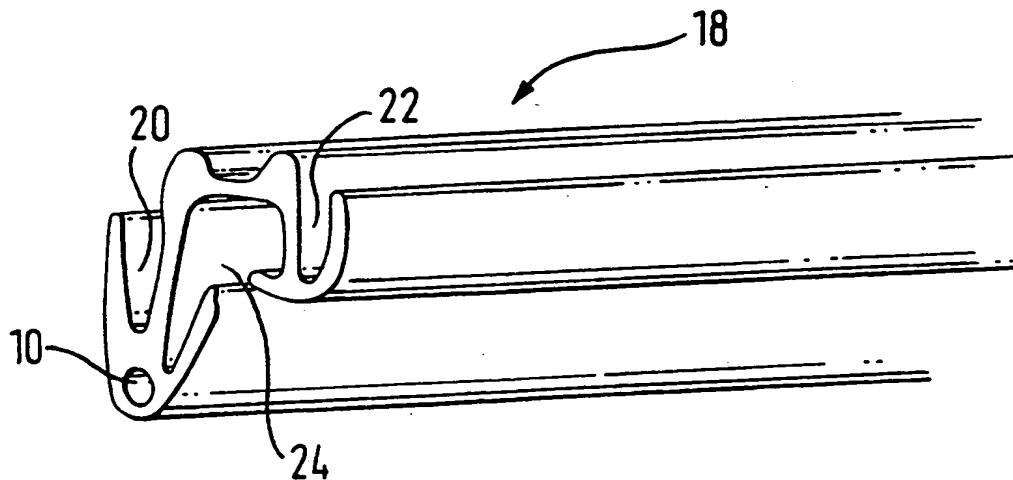

FIG. 4

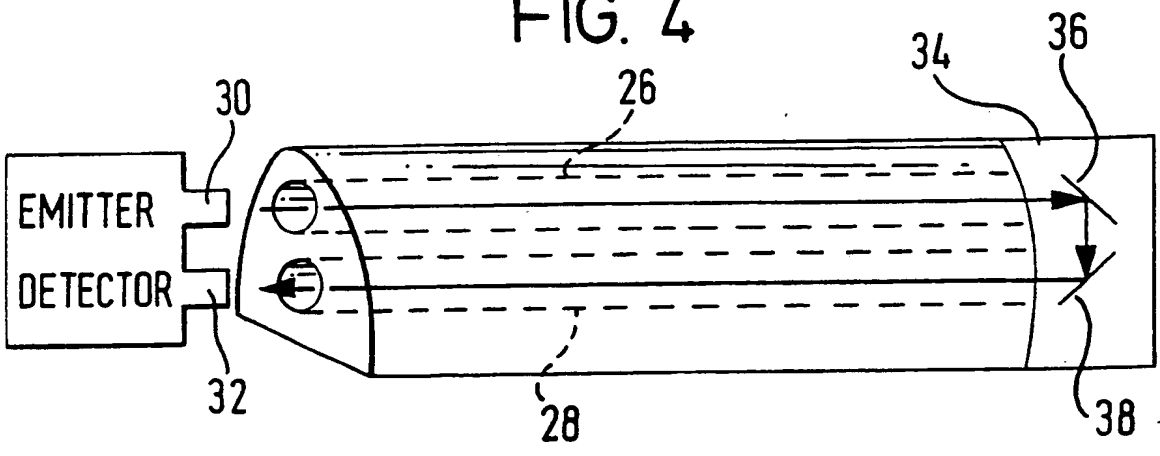
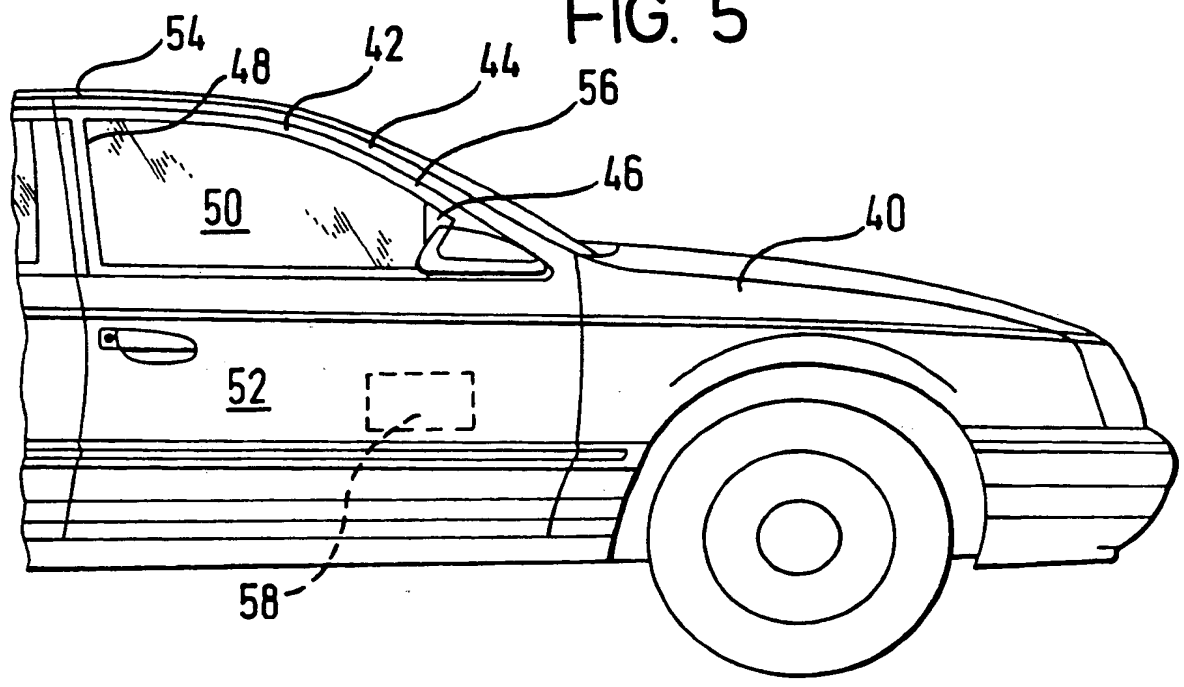

FIG. 5



DEFORMABLE SYSTEM

This invention relates to a deformable device intended to assist, for example, in the control of an electrically powered window pane when an object is trapped against an upper sealing member.

A number of safety systems have been developed to reduce the possibility of objects being trapped between the top of an upwardly moving window pane and the surround of a vehicle door or the like. Some systems have been developed to monitor the action of the motor with the aim of detecting a trapped body by sensing a change in the current drawn by, or the speed of, a motor powering an electrically operated window pane. These systems have been found to be sensitive to variations in door build and/or environmental conditions and therefore their reliability is poor.

Touch sensors are also known which may be based on many different technologies such as conductive rubber switches, piezo electrical cables, or piezo resistive films. In such cases the sensor is mounted in the upper window or door frame of a vehicle but this method has the drawback that the systems rely on significant squeezing of an obstruction to generate the force required to activate the system. Therefore, the trapped item is subjected to a significant force before it is detected and before the system is activated.

Also, no-touch sensors are known which use an infra-red or optical beam sent from an emitter positioned on the window or door frame and detected by a detector positioned across the window or door opening. Such sensors do not follow a curved contour shape of a window or door frame window spacing or the like and therefore may not be activated by a body trapped in the curved portion.

According to a first aspect of the present invention, there is provided a deformation detection

system comprising:

an elongate element including a deformable wall member which defines a radiation transmission path;

5 a radiation transmission source positioned to transmit radiation along the radiation transmission path; and

a radiation detector positioned to detect the radiation transmitted from said radiation source along the radiation transmission path;

10 the arrangement being such that a deformation of the wall member of the elongate element at least partially interrupts the radiation transmission path, whereby radiation being transmitted along the said path to the detector is attenuated.

15 The term "radiation" as used herein is the process by which energy is emitted from molecules and atoms owing to internal changes, as defined in Websters New International Dictionary (Second Edition).

20 The detector is capable of detecting an attenuation in the radiation being transmitted along the transmission path and producing a signal indicative of the detection of a deformation in the said wall member.

25 The surface of the wall member is preferably capable of reflecting radiation; this permits the radiation transmission path to be curved.

30 The wall member may be a wall of a bore in the said elongate member, so that the radiation transmission path is defined by the internal surface of the bore. For example, the elongate element may be in the form of a hollow tube. The bore defined by the internal surface conveniently has a circular cross-section, and, particularly where the radiation is in the form of a light wave, the internal surface is

35 preferably formed of a high gloss material.

The radiation transmission path may be divided

into two or more sections, operatively linked such that radiation transmitted down one section of the path from a proximal end may be transmitted along the other section of the path towards the radiation detector.

5 For example, where the radiation transmission path is defined by a bore within the elongate element, the bore may be divided into at least two sections linked by, for instance, a reflecting member, or other intervening device capable of receiving and retransmitting the  
10 radiation signal from the radiation transmission source. This would enable the two bores to be substantially parallel and would permit the transmission source and the detector to be conveniently positioned substantially adjacent one another at the  
15 same end of the bores. In such a case, in a preferred embodiment, one bore may be made stiffer than the other bore.

The transmission source and/or the detector may be positioned at respective ends of the radiation  
20 transmission path. When the said path is defined by a bore, each of the transmission source and/or the detector may be in the form of a removable plug, a portion of which can be positioned in the respective end of the bore.

25 In a preferred embodiment, the elongate element is a window pane sealing member capable of effecting sealing a window opening of a motor vehicle against a window pane. In this embodiment, the wall member of the elongate element may be deformed under the action  
30 of an object trapped between an electrically operated window pane as it closes and the periphery of the window opening about which the sealing member is positioned. On detection of attenuation in the radiation being transmitted along the transmission  
35 path, the detector produces a signal indicative of the detection of a deformation in the wall member, and this

may be used to control the operation of the window drive or wind mechanism. For instance, the signal may be used to control (e.g. stop or reverse) the action of the motor driving the window. Preferably, the radiation transmission source and radiation detector are energized only when the window pane is closing or attempting to close.

According to a second aspect of the present invention, there is provided a motor vehicle having a body opening in which a closure member is movable towards a peripheral edge of the body opening to close the opening, an electrically operated drive mechanism being provided to effect movement of the closure member;

characterised in that said peripheral edge of the body opening is provided with a deformation detection device comprising:

(a) an elongate element including a deformable wall member which defines a radiation transmission path, the arrangement being such that a deformation of the wall member of the elongate element at least partially interrupts the radiation transmission path, whereby radiation being transmitted along the said path to the detector is attenuated;

(b) a radiation transmission source positioned to transmit radiation along the radiation transmission path; and

(c) a radiation detector positioned to detect an attenuation in the radiation transmitted from said radiation source along the radiation transmission path; and

(d) means for controlling operation of said drive mechanism in response to detection by the detection device of an attenuation in the radiation transmitted from the radiation source.

The deformation of the wall member of the

elongate element may be as a consequence of an object becoming trapped between the device and the closure member.

The body opening may be a window opening in which case the closure member is a window pane. Alternatively, the body opening may be an opening in the roof of the vehicle (a "sun roof" opening), in which case the closure member is a sun roof member. In either of these cases, the deformable device may be part of a sealing member around the periphery of the body opening.

The drive mechanism may include an electric motor.

The drive mechanism may be controlled in such a way that movement of the closure member is stopped or reversed, so as to prevent the trapped object from being crushed and to permit release of the trapped object. In an alternative embodiment, the drive mechanism can be disabled. Preferably, the radiation transmission source and the radiation detector are only energized when the drive mechanism moves, or attempts to move, the closure member.

The radiation transmitting source in both aspects of the invention may be a source of light waves, for instance an infra-red radiation source. In a preferred embodiment, the infra-red radiation from the transmitting source may be modulated. Alternatively, instead of transmitting visible or non-visible light waves (such as infra-red waves), the radiation transmission source may emit audible or inaudible (i.e. ultrasound) sound waves to be detected by the radiation detector. If an audible sound source is used, it may act as a warning that the window pane or closure member is closing. In one embodiment, the note of the audible sound may change to serve as a warning of a trapped object.

For a better understanding of the present



invention and to show how the same may be carried into effect, reference will now be made, by way of example, to the accompanying drawings, in which:-

5 Figure 1 is a perspective view of one embodiment of the present invention;

Figure 2 is a longitudinal sectional view of the embodiment shown in Figure 1;

Figure 3 is a perspective view of another embodiment of the present invention;

10 Figure 4 is a perspective view of yet another embodiment of the present invention; and

Figure 5 shows a side view of a vehicle in which the present invention may be used.

Referring firstly to Figure 1, there is shown a  
15 tubular member shown generally at 2, a radiation transmitting source 4 and a radiation detector 6. The tubular member 2 is hollow and has a bore 10 having an internal surface 8 having a high gloss finish. Radiation is transmitted from the transmitting source 4  
20 to the detector 6 along the bore 10. This is shown in greater detail in Figure 2. A first beam 12 may be transmitted through the centre of the bore 10 of tubular member 2 without touching the internal surface 8. However, a second radiation beam 14 which is  
25 transmitted from the transmitting source 4 does not pass through the central region of the bore 10, but instead hits the internal surface 8 at incident points 16A and 16B. The second radiation beam 14 is reflected  
30 by the internal surface 8 at points 16A and 16B due to the high gloss finish. In this way, the second radiation beam 14 may pass down the bore 10 and reaches the detector 6 shown in Figure 1.

As the tubular member 2 is made of a deformable material, deformation of the tubular member 2 causes  
35 deformation of the internal surface 8 and thereby restricts the size of the opening of the bore 10. When

the size of the opening of the bore 10 is so restricted, the detector 6 detects attenuated radiation from the transmitting source 4. Whilst it is not shown in the drawings, the detector may be connected to a motor in such a manner that when deformation of the tubular member 2 is detected by detection of attenuated radiation, the motor can be stopped and/or reversed. Therefore, if the motor is controlling an electrically powered window pane, the continued rising of the window pane will be stopped and/or reversed on deformation of tubular member 2.

Turning now to Figure 3 there is shown a window sealing member shown generally at 18. The sealing member 18 has a bore 10 of the same form as shown in Figures 1 and 2. The sealing member 18 also comprises flange receiving portions 20 and 22, and a glazing panel receiving channel 24. Flange receiving portions 20 and 22 enable attachment of sealing member 18 to, for example, a header portion of a window or door frame joining "A" and "B" pillars of the front door. The glazing panel receiving channel 24 receives a glazing panel (not shown), which is movable in an upward and downward direction, when such a glazing panel is in its fully upward configuration. As discussed in relation to Figures 1 and 2 a radiation transmission source and a radiation detecting source can be placed at either end of the bore 10. When a glazing panel moves towards its upward position, a body trapped between it and the sealing member 18 will deform the bore 10 and thereby stop the upward movement of the glazing panel or even reverse that upward movement by detection of attenuated radiation.

In a further embodiment shown in Figure 4, which can also be adapted to be formed in a weatherstrip shown in Figure 3, there is shown a first bore section 26 and a second bore section 28 running substantially

parallel thereto. At one end of the first bore section 26 and second bore section 28 there is positioned a radiation transmitting source 30 and a radiation detector 32 of a form suitable for plugging into a first bore section 26 and second bore section 28, respectively. Plugged into the opposite ends of first bore section 26 and second bore section 28 is a radiation reflecting member 34, the radiation reflecting member 34 comprising two mirrors 36, 38. The bore sections 26 and 28 are of the form shown in Figures 1 to 3. In use, radiation from the transmitting source 30 travels down the first bore section 26, is reflected by mirrors 36 and 38 and is then transmitted along second bore section 28 to the detector. As previously, the detector is able to detect an attenuation in transmitted radiation and thus deformation of one or both of the bore sections 26, 28 and may thereby stop or reverse a motor to which it is connected. The embodiment shown in Figure 4 allows both the transmitting source 30 and detector 32 to be positioned at one end of the bore sections 26, 28. In a preferred embodiment, one of the bore sections 26 or 28 may be made stiffer than the other bore section. When a body is trapped, the less stiff bore section collapses and attenuates the radiation detected by the detector 32. The stiffer bore section would then deflect at higher loads but may also allow overtravel so that there is sufficient time for the electrical system to which the detector is connected to respond.

30

Figure 5 shows a vehicle 40 in which a sealing member 42 is positioned on a header portion 44 connecting "A" pillar 46 and "B" pillar 48. The sealing member 42 is of the form of that shown in Figure 3, but may be of any suitable form for being positioned on or adjacent the header portion 44. The

35

vehicle 40 has a door 52 within which a window pane 50 is positioned. The window pane 50 is movable in an upward and downward motion within door 52 . The sealing member 42 has a bore, as shown in Figure 3. A  
5 radiation transmitter (not shown) is positioned in the region of end 54 of the sealing member 42 and a detector (not shown) in the region of end 56 of the sealing member at the other end of the bore. The  
10 detector is connected to a motor 58 which controls the upward and downward motion of the window pane 50. In use, the transmitter transmits a radiation signal along the bore to the detector. As the motor 58 causes the  
15 upward motion of the window pane 50, an object trapped between it and sealing member 42 deforms the bore and the detector then detects an attenuated signal from the transmitter and stops the motor 58 which therefore stops the upward movement of window pane 50 preventing significant crushing of the trapped object.

CLAIMS

1. A deformation detection system comprising:  
an elongate element including a deformable wall  
member which defines a radiation transmission path;  
5 a radiation transmission source positioned to  
transmit radiation along the radiation transmission  
path; and  
a radiation detector positioned to detect the  
radiation transmitted from said radiation source along  
10 the radiation transmission path;  
the arrangement being such that a deformation of  
the wall member of the elongate element at least  
partially interrupts the radiation transmission path,  
whereby radiation being transmitted along the said path  
15 to the detector is attenuated.
2. A deformation detection system according to  
claim 1, wherein the detector is capable of detecting  
an attenuation in the radiation being transmitted along  
the transmission path and producing a signal indicative  
20 of the detection of a deformation in the said wall  
member.
3. A deformation detection system according to  
claim 1 or 2, wherein the surface of the wall member  
defining the radiation transmission path is capable of  
25 reflecting radiation.
4. A deformation detection system according to  
any preceding claim, wherein the wall member is a wall  
of a bore in the said elongate element, and wherein the  
radiation transmission path is defined by the internal  
30 surface of the bore.
5. A deformation detection system according to  
claim 4, wherein the elongate element is in the form of  
a hollow tube.
6. A deformation detection system according to  
35 claim 4 or 5, wherein the bore has a circular cross-  
section.

7. A deformation detection system according to any one of claims 4 to 6, wherein the internal surface of the bore is formed of a high gloss material.

8. A deformation detection system according to  
5 any preceding claim, wherein the radiation transmission path is divided into two or more sections, operatively linked such that radiation transmitted down one section of the path from a proximal end may be transmitted along the other section of the path towards the  
10 radiation detector.

9. A deformation detection system according to claim 8, wherein, when the radiation transmission path is defined by a bore within the elongate member, the bore is divided into at least two sections linked by an  
15 intervening device capable of receiving and retransmitting the radiation signal from the radiation transmission source.

10. A deformation detection system according to claim 9, wherein the intervening device is a reflecting  
20 member.

11. A deformation detection system according to claim 9 or 10, wherein, when the transmission path is defined by two substantially parallel sections, the transmission source and detector are positioned  
25 substantially adjacent one another at the same end of the sections.

12. A deformation detection system according to claim 11, wherein one bore section is stiffer than the other bore section.

13. A deformation detection system according to  
30 any preceding claim, wherein the transmission source and/or the detector are positioned at respective ends of the radiation transmission path.

14. A deformation detection system according to  
35 claim 4 or any one of claims 5 to 13 when appendant to claim 4, wherein the transmission source and/or the

detector is in the form of a removable plug, a portion of which is positioned in the respective end of the bore.

5 15. A deformation detection system according to any preceding claim, wherein the elongate element is a window pane sealing member capable of effecting sealing a window opening of a motor vehicle against a window pane.

10 16. A deformation detection system according to claim 15, wherein the wall member of the elongate element is deformed under the action of an object trapped between an electrically operated window pane as it closes and the periphery of the window opening about which the sealing member is positioned.

15 17. A deformation detection system according to claim 15 or 16, wherein, on detection of attenuation in the radiation being transmitted along the transmission path, the detector produces a signal indicative of the detection of a deformation in the wall member, and this  
20 is used to control the operation of a window drive or wind mechanism.

18. A deformation detection system according to claim 17, wherein the signal is used to control the action of a motor driving the window.

25 19. A deformation detection system according to any one of claims 15 to 18, wherein the radiation transmission source and radiation detector are energized only when the window pane is closing or attempting to close.

30 20. A motor vehicle having a body opening in which a closure member is movable towards a peripheral edge of the body opening to close the opening, an electrically operated drive mechanism being provided to effect movement of the closure member;

35 characterised in that said peripheral edge of the body opening is provided with a deformation detection

device comprising:

(a) an elongate element including a deformable wall member which defines a radiation transmission path, the arrangement being such that a deformation of  
5 the wall member of the elongate element at least partially interrupts the radiation transmission path, whereby radiation being transmitted along the said path to the detector is attenuated;

(b) a radiation transmission source positioned to  
10 transmit radiation along the radiation transmission path; and

(c) a radiation detector positioned to detect an attenuation in the radiation transmitted from said radiation source along the radiation transmission path;  
15 and

(d) means for controlling operation of said drive mechanism in response to detection by the detection device of an attenuation in the radiation transmitted from the radiation source.

20 21. A motor vehicle according to claim 20, wherein the deformation of the wall member is as a consequence of an object being trapped between the deformation detection device and the closure member.

25 22. A motor vehicle according to claim 20 or 21, wherein the body opening is a window opening and the closure member is a window pane.

23. A motor vehicle according to claim 20 or 21, wherein the body opening is an opening in the roof of the vehicle and the closure member is a sunroof member.

30 24. A motor vehicle according to any one of claims 20 to 23, wherein the deformation detection device is part of a sealing member around the periphery of the body opening.

35 25. A motor vehicle according to any one of claims 20 to 24, wherein the drive mechanism is an electric motor.



26. A motor vehicle according to any one of claims 20 to 24, wherein the drive mechanism is controlled in such a way that movement of the closure member is stopped or reversed so as to prevent an object trapped between the deformation device and the closure member from being crushed and to permit its release.

27. A motor vehicle according to any one of claims 20 to 25, wherein the drive mechanism is disabled on trapping an object between the deformation device and the closure member.

28. A motor vehicle according to any one of claims 20 to 27, wherein the radiation transmission source and the radiation detector are only energized when the drive mechanism moves, or attempts to move, the closure member.

29. A deformation detection system or motor vehicle according to any preceding claim, wherein the radiation transmission source is a source of light waves.

30. A deformation detection system or motor vehicle according to claim 29, wherein the source of light waves is an infra-red radiation source.

31. A deformation detection system or motor vehicle according to claim 30, wherein the infra-red radiation is modulated.

32. A deformation detection system or motor vehicle according to any one of claims 1 to 28, wherein the radiation transmission source emits audible or inaudible sound waves to be detected by the radiation detector.

33. A deformation detection system or motor vehicle according to claim 32 when appendant to any one of claims 15 to 28, wherein, when an audible sound source is used, it acts as a warning that the window pane or closure member is closing.

34. A deformation detection system or motor vehicle according to claim 33, wherein the note of the audible sound may change to serve as a warning of a trapped object.

5        35. A deformation detection device substantially as hereinbefore described with reference to, and as illustrated in, Figures 1 to 4 of the accompanying drawings.

10       36. A motor vehicle substantially as hereinbefore described with reference to, and as illustrated in, Figure 5 of the accompanying drawings.

**Amendments to the claims have been filed as follows**

1. A deformation detection system comprising:  
an elongate element including a deformable wall  
member which defines a radiation transmission path;  
5 a sound radiation transmission source positioned  
to transmit radiation in the form of audible or  
inaudible sound waves along the radiation transmission  
path; and

10 a sound radiation detector positioned to detect  
the radiation transmitted from said radiation source  
along the radiation transmission path, which radiation  
detector is provided with a means for monitoring an  
attenuation of the radiation;

15 the arrangement being such that a deformation of  
the wall member of the elongate element at least  
partially interrupts the radiation transmission path,  
whereby radiation being transmitted along the said path  
to the detector is attenuated.

2. A deformation detection system according to  
20 claim 1, wherein the detector is capable of producing a  
signal indicative of the detection of a deformation in  
the said wall member.

3. A deformation detection system according to  
claim 1 or 2, wherein the surface of the wall member  
25 defining the radiation transmission path is capable of  
reflecting radiation.

4. A deformation detection system according to  
any preceding claim, wherein the wall member is a wall  
of a bore in the said elongate element, and wherein the  
30 radiation transmission path is defined by the internal  
surface of the bore.

5. A deformation detection system according to  
claim 4, wherein the elongate element is in the form of  
a hollow tube.

35 6. A deformation detection system according to  
claim 4 or 5, wherein the bore has a circular cross-

section.

7. A deformation detection system according to any one of claims 4 to 6, wherein the internal surface of the bore is formed of a highly reflective material.

5 8. A deformation detection system according to any preceding claim, wherein the radiation transmission path is divided into two or more sections, operatively linked such that radiation transmitted down one section of the path from a proximal end may be transmitted  
10 along the other section of the path towards the radiation detector.

9. A deformation detection system according to claim 8, wherein, when the radiation transmission path is defined by a bore within the elongate member, the  
15 bore is divided into at least two sections linked by an intervening device capable of receiving and retransmitting the radiation signal from the radiation transmission source.

10. A deformation detection system according to  
20 claim 9, wherein the intervening device is a reflecting member.

11. A deformation detection system according to claim 9 or 10, wherein, when the transmission path is defined by two substantially parallel sections, the  
25 transmission source and detector are positioned substantially adjacent one another at the same end of the sections.

12. A deformation detection system according to claim 11, wherein one bore section is stiffer than the  
30 other bore section.

13. A deformation detection system according to any preceding claim, wherein the transmission source and/or the detector are positioned at respective ends of the radiation transmission path.

35 14. A deformation detection system according to claim 4 or any one of claims 5 to 13 when appendant to

claim 4, wherein the transmission source and/or the detector is in the form of a removable plug, a portion of which is positioned in the respective end of the bore.

5           15. A deformation detection system according to any preceding claim, wherein the elongate element is a window pane sealing member capable of effecting sealing a window opening of a motor vehicle against a window pane.

10           16. A deformation detection system according to claim 15, wherein the wall member of the elongate element is deformed under the action of an object trapped between an electrically operated window pane as it closes and the periphery of the window opening about  
15 which the sealing member is positioned.

          17. A deformation detection system according to claim 15 or 16, wherein, on detection of attenuation in the radiation being transmitted along the transmission path, the detector produces a signal indicative of the  
20 detection of a deformation in the wall member, and this is used to control the operation of a window drive or wind mechanism.

          18. A deformation detection system according to claim 17, wherein the signal is used to control the  
25 action of a motor driving the window.

          19. A deformation detection system according to any one of claims 15 to 18, wherein the radiation transmission source and radiation detector are energized only when the window pane is closing or  
30 attempting to close.

          20. A motor vehicle having a body opening in which a closure member is movable towards a peripheral edge of the body opening to close the opening, an electrically operated drive mechanism being provided to  
35 effect movement of the closure member;  
          characterised in that said peripheral edge of the

body opening is provided with a deformation detection device comprising:

5 (a) an elongate element including a deformable wall member which defines a radiation transmission path, the arrangement being such that a deformation of the wall member of the elongate element at least partially interrupts the radiation transmission path, whereby radiation being transmitted along the said path to the detector is attenuated;

10 (b) a sound radiation transmission source positioned to transmit radiation in the form of audible or inaudible sound waves along the radiation transmission path; and

15 (c) a sound radiation detector positioned to detect an attenuation in the radiation transmitted from said radiation source along the radiation transmission path, which radiation detector is provided with a means for monitoring an attenuation of the radiation; and

20 (d) means for controlling operation of said drive mechanism in response to detection by the detection device of the attenuation in the radiation transmitted from the radiation source.

21. A motor vehicle according to claim 20, wherein the deformation of the wall member is as a consequence of an object being trapped between the deformation detection device and the closure member.

22. A motor vehicle according to claim 20 or 21, wherein the body opening is a window opening and the closure member is a window pane.

30 23. A motor vehicle according to claim 20 or 21, wherein the body opening is an opening in the roof of the vehicle and the closure member is a sunroof member.

35 24. A motor vehicle according to any one of claims 20 to 23, wherein the deformation detection device is part of a sealing member around the periphery of the body opening.

25. A motor vehicle according to any one of claims 20 to 24, wherein the drive mechanism is an electric motor.

5 26. A motor vehicle according to any one of claims 20 to 24, wherein the drive mechanism is controlled in such a way that movement of the closure member is stopped or reversed so as to prevent an object trapped between the deformation device and the closure member from being crushed and to permit its  
10 release.

27. A motor vehicle according to any one of claims 20 to 25, wherein the drive mechanism is disabled on trapping an object between the deformation device and the closure member.

15 28. A motor vehicle according to any one of claims 20 to 27, wherein the radiation transmission source and the radiation detector are only energized when the drive mechanism moves, or attempts to move, the closure member.

20 29. A deformation detection system or motor vehicle according to any preceding claim, wherein, when an audible sound source is used, it acts as a warning that the window pane or closure member is closing.

25 30. A deformation detection system or motor vehicle according to claim 29, wherein the note of the audible sound may change to serve as a warning of a trapped object.

30 31. A deformation detection device substantially as hereinbefore described with reference to, and as illustrated in, Figures 1 to 4 of the accompanying drawings.

32. A motor vehicle substantially as hereinbefore described with reference to, and as illustrated in, Figure 5 of the accompanying drawings.

<b>Patents Act 1977</b> <b>Examiner's report to the Comptroller under Section 17</b> <b>(The Search report)</b>	Application number GB 9413398.0
<b>Relevant Technical Fields</b>  (i) UK CI (Ed.M)      G1A (AME) E2M (MAB) G3N (NG2) (ii) Int CI (Ed.5)      E05F 15/00, 15/20 G01V 9/04	Search Examiner M GILLARD
<b>Databases (see below)</b> (i) UK Patent Office collections of GB, EP, WO and US patent specifications.	Date of completion of Search 22 NOVEMBER 1994
(ii) ONLINE DATABASES: WPI	Documents considered relevant following a search in respect of Claims :- 1 TO 36

**Categories of documents**

<b>X:</b> Document indicating lack of novelty or of inventive step.	<b>P:</b> Document published on or after the declared priority date but before the filing date of the present application.
<b>Y:</b> Document indicating lack of inventive step if combined with one or more other documents of the same category.	<b>E:</b> Patent document published on or after, but with priority date earlier than, the filing date of the present application.
<b>A:</b> Document indicating technological background and/or state of the art.	<b>&amp;:</b> Member of the same patent family; corresponding document.

Category	Identity of document and relevant passages	Relevant to claim(s)
X	GB 2236388 A      (HERGA) page 5 line 20 to page 6 line 16	1 to 4, 6, 13, 29
X	GB 2112934 A      (KALERVO) whole document	1 to 7, 13, 29
X	EP 0560047 A1      (BOSCH) whole document	1, 3, 4, 5, 13, 15, 16 to 22, 24 to 28, 32
X	EP 0259573 A1      (BOSCH) whole document	1 to 4, 6, 13, 15 to 18, 20 to 27, 29
X	US 4944116      (MEWALD) whole document	1 to 7, 13, 20, 21, 24 to 27, 29
X	DE 3107847 A1      (METALLWORK...) whole document	1 to 7, 13 to 18, 20 to 22, 25 to 27

Databases: The UK Patent Office database comprises classified collections of GB, EP, WO and US patent specifications as outlined periodically in the Official Journal (Patents). The on-line databases considered for search are also listed periodically in the Official Journal (Patents).



Continuation page

Category	Identity of document and relevant passages	Relevant to claim(s)
X	PATENT ABSTRACTS OF JAPAN, Volume 10, No. 29 (M-451); and JP-A-60-185626 (NIPPON DENSO) see abstract	1 to 4, 13, 15 to 18, 20 to 22, 24 to 27, 29
X	PATENT ABSTRACTS OF JAPAN, Volume 8, No. 253 (M-339); and JP-A-59-128009 (NIPPON DENSO) see abstract	1 to 4, 13, 15 to 18, 20 to 22, 24 to 27, 29

**THIS PAGE BLANK (USPTO)**